



El medidor eléctrico ELNet VIP es un medidor compacto, multifuncional y trifásico, especialmente diseñado para satisfacer las estrictas necesidades de medición de potencia en cualquier instalación eléctrica.

## Technical Data

Power Requirements:	90 ~ 250 VAC 110 ~ 280 VDC 60/50 Hz 9VA
Dimensions (HxWxD):	96 x 96 x 80 mm
Shipping Weight:	0.45 Kg.
Environmental:	
Operation.	-20 ~ +70 °C
Storage.	-20 ~ +70 °C
Humidity	0 ~ 95 RH% non-condensing
Front Panel Protection	IP64

## Input & Output Rating

Accuracy:	Active energy 0.5% FS Reactive energy 0.5% FS
Voltage: Line-Line	0 ~ 550 VAC RMS
Line-Neutral	0 ~ 320 VAC RMS
Maximum Burden	1000V RMS Continuous < 0.06VA
Current: Rated	0-5 A
Overload	50 A RMS Continuous
Withstand Burden	100 A for 1 minute < 0.05 VA
Display:	High resolution backlight display
Maximum Input Voltage:	1000V
Maximum Input Current:	6A

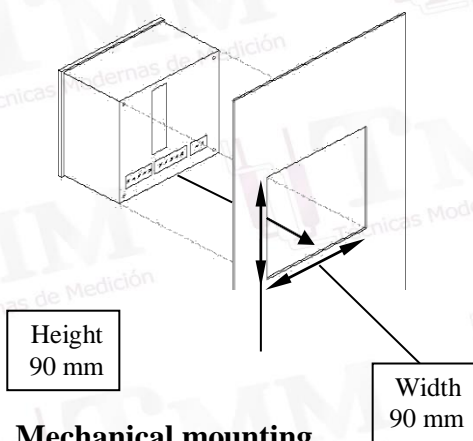

## Mechanical mounting

## Valores de Medición y Visualización

Parámetros de Medición	Display Range in direct connection (scaling factor 1)	Measuring in direct connection (scaling factor 1)	Visualización en Display
Current	0.01 – 6A	0.01 – 6A	0.01 – 999MA
Voltage L-N	0.00 – 550 V	0.00 – 550 V	0.001 – 999MV
Voltage L-L	0.00 – 950 V	0.00 – 950 V	0.001 – 999MV
Frequency (Hz)	45.1-65.1 Hz	45.1-65.1 Hz	45.1-65.1 Hz
Active power total phase			0.00W – 999MW
Reactive power total phase			0.00VAR -999MVAR
Apparent power total phase			0.00VA -999MVA
Power Factor (cap.\ind.)	-1.00 ÷ 1.00	-1.00 ÷ 1.00	-1.00 ÷ 1.00

## Standards

- IEC 60051-03
- EN 55022, Class A, Amendments A1; A2
- EN 55024, Amendments A1; A2
- EN 61000-3-2, Class A
- EN 61000-3-3, Amendment A1
- IEC 61000-4-2
- IEC 61000-4-3
- IEC 61000-4-4
- IEC 61000-4-5
- IEC 61000-4-6
- IEC 61000-4-11

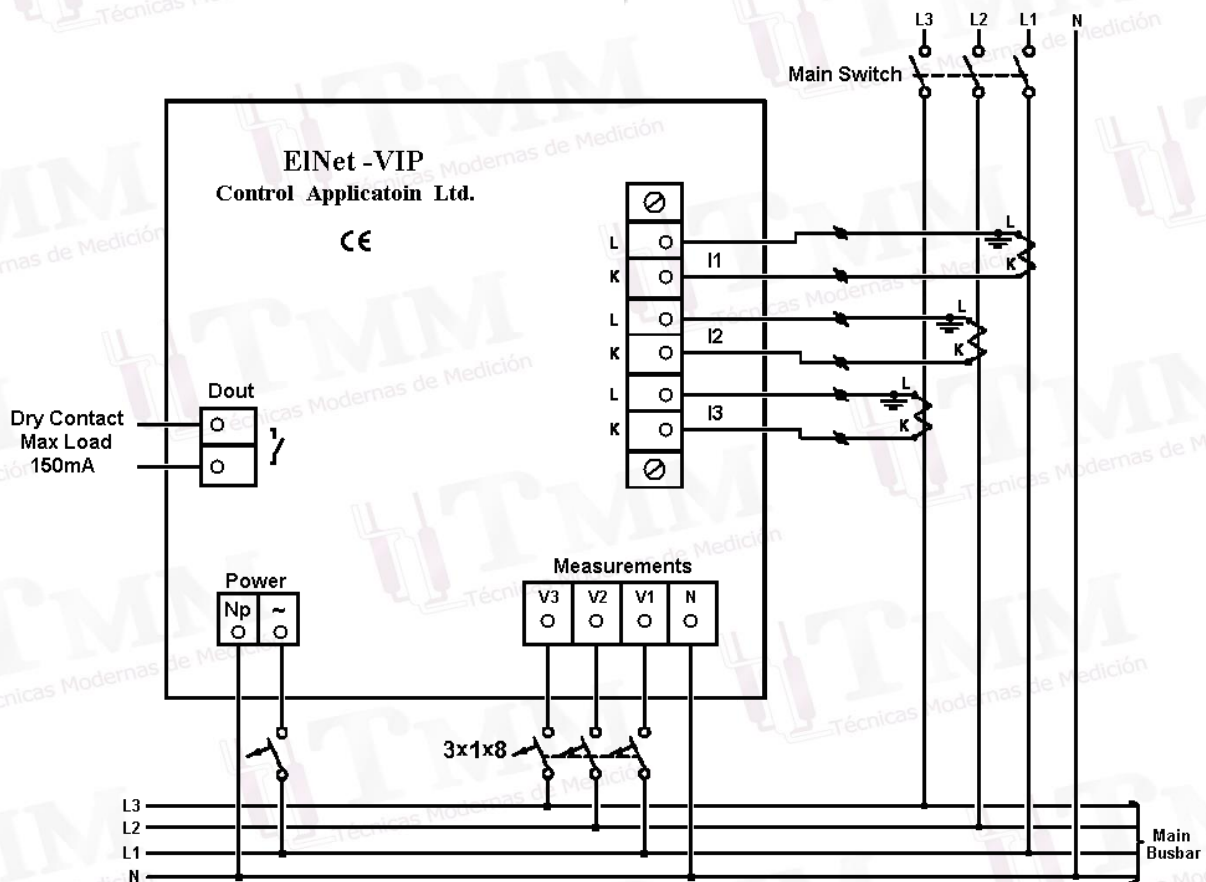

## Wiring Diagram Example